

SENSYLINK Microelectronics

(CA9554/CA9554A)

Low-Voltage 8-Bit I2C/SMBus I/O Expander with Interrupt Output and Configurations

CA9554/CA9554A is an 8-Bit remote GPIO expander. It provides remote GPIO expansion for most MCU families via the I²C or SMBus interface.

It is ideally used in Server and Telecom equipment.

Low-Voltage 8-Bit I2C/SMBus I/O Expander with Interrupt Output and Configurations

1. Description

The chip is 8-bit I/O expander. It provides remote GPIO expansion for most MCU families via the I2C or SMBus interface. The CA9554/CA9554A has 8-bit Input Port register, Output Port register, Configuration register (setup as input or output), and Polarity Inversion register (active high or active low). After power on, the 8 I/O pins are configured as inputs with an internal weak pull-up to V_{CC}. However, the master can enable the I/O as either inputs or outputs individually by setup the configuration register bits. If no external signals are applied to the CA9554/CA9554A I/O pins, the voltage level is 1 or high due to the internal pull-up resistors. The data for each input or output is stored in the corresponding input or output port register. The polarity of the Input Port register can be inverted with the Polarity Inversion register. All registers can be read by the master.

The master can reset the chip probably caused by timeout or other improper operation using the power-on reset feature, which resets all registers in their default state and initializes the I2C/SMBus state machine. The chip has outputs latch feature, which can protect the chip when driving LEDs directly with high-current capability.

Three hardware pins (A0, A1, A2) vary the fixed I2C-bus address and allow up to eight devices to share the same I2C-bus/SMBus. The PCA9554A is identical to the PCA9554 except that the fixed I2C-bus address is different allowing up to sixteen of these devices (eight of each) on the same I2C-bus/SMBus.

The CA9554 interrupt pin is used to indicate to the system master that an input data state has changed.

Available Package: TSSOP-16, QFN4x4-16, QFN3x3-16 package.

2. Features

- Operation Voltage: 1.65V to 5.5V
- Low standby current
- 5.0V Tolerance I/O Port
- Remote 8-bit GPIO Expander
- Compatible with SMBus and I2C interface
- I2C Speed up to 1.0MHz (Fast Mode Plus)
- Up to 8 slave addresses
- Open-Drain Active-Low Interrupt Output
- Input, Output and Configuration Register
- Polarity Inversion Register
- Built-in Power-on Reset
- No Glitch during Power-up
- Noise Filter on SCL/SDA inputs
- 8 I/O pins
 - As Input internal pull-up resistor (default)
 - As Output with push-pull
- Latch feature when driving LEDs directly with high current capability
- Temperature Range: -40°C to 85°C

3. Application

- Server, Notebook PC
- Telecom equipment

4. PIN Configurations (Top View)

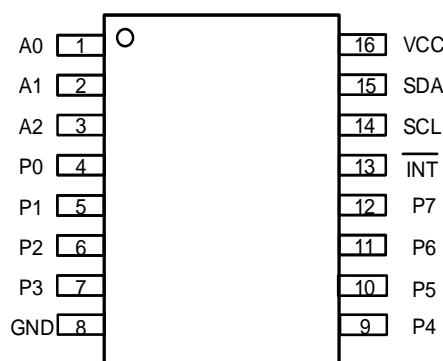

TSSOP-16(Package Code MT)

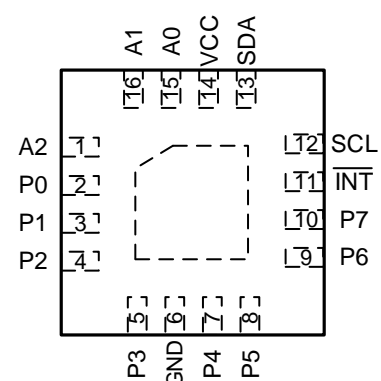

QFN4x4-16/QFN3x3-16(Package Code QN/QNA)

Low-Voltage 8-Bit I2C/SMBus I/O Expander with Interrupt Output and Configurations

5. Typical Application

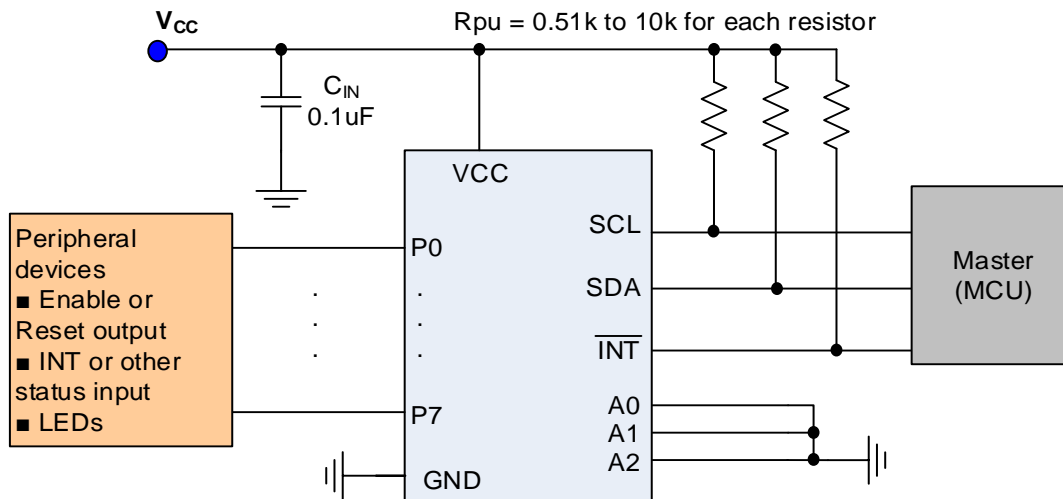

Figure 1 Typical Application of CA9554/CA9554A

6. Pin Description

PIN Name	PIN No.		Description
	TSSOP-16	QFN4x4-16 QFN3x3-16	
A0	1	15	Slave addresses setup pins, which can generate slave addresses by connecting these pins to GND or VCC respectively.
A1	2	16	
A2	3	1	
P0	4	2	GPIO bit0, output: push-pull structure; input: internal pull-up weakly structure.
P1	5	3	GPIO bit1, output: push-pull structure; input: internal pull-up weakly structure.
P2	6	4	GPIO bit2, output: push-pull structure; input: internal pull-up weakly structure.
P3	7	5	GPIO bit3, output: push-pull structure; input: internal pull-up weakly structure.
GND	8	6	Ground pin.
P4	9	7	GPIO bit4, output: push-pull structure; input: internal pull-up weakly structure.
P5	10	8	GPIO bit5, output: push-pull structure; input: internal pull-up weakly structure.
P6	11	9	GPIO bit6, output: push-pull structure; input: internal pull-up weakly structure.
P7	12	10	GPIO bit7, output: push-pull structure; input: internal pull-up weakly structure.
$\overline{\text{INT}}$	13	11	Interrupt output with active low. Connect to VCC through a pullup resistor
SCL	14	12	Digital interface clock input pin, need a pull-up resistor to VCC.
SDA	15	13	Digital interface data input or output pin, need a pull-up resistor to VCC.
VCC	16	14	Power supply input pin, using 0.1uF low ESR ceramic capacitor to ground

Low-Voltage 8-Bit I2C/SMBus I/O Expander with Interrupt Output and Configurations

7. Function Block

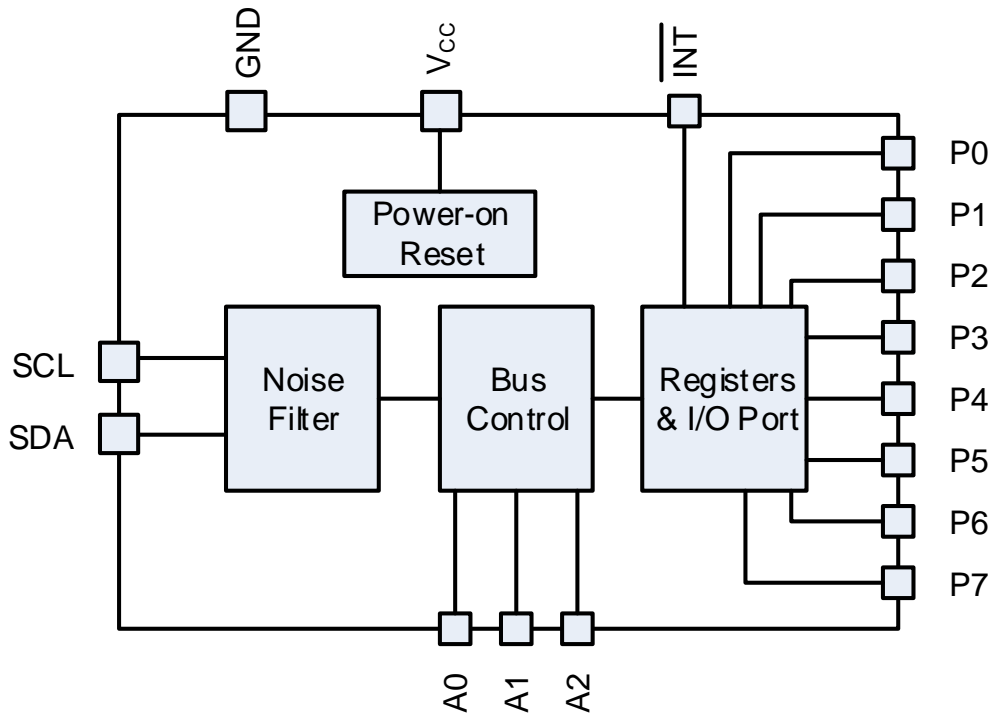
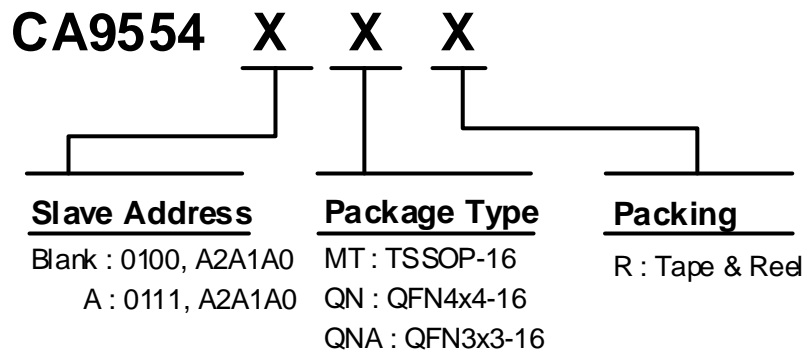

Figure 2 CA9554/CA9554A Function Block

Low-Voltage 8-Bit I2C/SMBus I/O Expander with Interrupt Output and Configurations

8. Ordering Information



Order PN	Green ¹	Package	Marking ID ²	Packing	MPQ	Operation Temperature
CA9554MTR	Halogen free	TSSOP-16	9554 YWWAXX	Tape & Reel	4,000	-40°C~+85°C
CA9554QNR	Halogen free	QFN4x4-16	9554 YWWAXX	Tape & Reel	5,000	-40°C~+85°C
CA9554QNAR	Halogen free	QFN3x3-16	9554 YWWAXX	Tape & Reel	3,000	-40°C~+85°C
CA9554AMTR	Halogen free	TSSOP-16	9554A YWWAXX	Tape & Reel	4,000	-40°C~+85°C
CA9554AQNR	Halogen free	QFN4x4-16	9554A YWWAXX	Tape & Reel	5,000	-40°C~+85°C
CA9554AQNAR	Halogen free	QFN3x3-16	9554A YWWAXX	Tape & Reel	3,000	-40°C~+85°C

Notes:

1. Sensylink can meet RoHS 2.0/REACH requirement. So, most package types Sensylink offers only states halogen free, instead of lead free.
2. Marking ID includes 2 rows of characters. In general, the 1st row of characters is part number, and the 2nd row of characters are date code plus production information.

***SENSYLINK Microelectronics Inc.***

www.sensylink.com

IMPORTANT NOTICE

SENSYLINK Microelectronics Inc. reserves the right to make modifications, enhancements, improvements, corrections or other changes without further notice to this document and any product described herein or to discontinue any product or service. Customers should obtain the latest relevant information before placing orders and should verify the latest and complete information. SENSYLINK Microelectronics does not assume any responsibility for use of any product, nor does SENSYLINK Microelectronics any liability arising out of the application or use of this document or any product or circuit described herein. SENSYLINK Microelectronics assumes no liability for applications assistance or the design of Customers' products. Customers are responsible for their products and applications using SENSYLINK Microelectronics components. SENSYLINK Microelectronics does not convey any license under its patent or trademark rights nor the other rights.

SENSYLINK Microelectronics Inc. © 2015 - 2023.