

SENSYLINK Microelectronics

(CT7424)

4-CH Remote and 1-CH Local Temperature Sensor

CT7424 is a 5-channels (4-channels Remote and 1-channel Local) Temperature Sensor with $\pm 1^{\circ}\text{C}$ Accuracy and SMBus Digital Interface.

It is ideally used in Temperature Sensing and Monitoring Systems, such as Computer, Server and Telecom Equipment System etc.

±1.0°C 5-CH (4-CH Remote and 1-CH Local) Digital Temperature Sensor

Description

The CT7424 is a 5-channel digital temperature sensor with ±1°C accuracy. Temperature data can be read out directly via SMBus/I²C interface by MCU or SoC chip.

CT7424 has 5 independent channels: 4 remote and 1 local. The remote channels could be connected to an external Diode, BJT transistor (diode-connected mode), or parasitic PNP BJT transistor inside the CPU, FPGA or SOC chip. Based on this, this chip can be used to monitor CPU, GPU, MCU, SOC, FPGA or DSP chip die and case temperature.

Each chip is calibrated in factory before shipment to customers. There is no need for re-calibration anymore for ±1°C accuracy. It includes a band-gap circuit, an Analog to Digital converter, a calibration unit with non-volatile memory and a digital interface block.

It integrates a 13-bit ADC, which can offer 0.0625°C resolution and -55°C to 150°C temperature range. There are 2 individual thermal limit registers for each channel, which can be programmed from -255°C to 255°C range with 0.5°C step as threshold temperature. It has 2 logic THERM output pins (THERM, THERM2) with open drain structure and active low.

Available Package: QFN3x3-16.

Features

- Operation Voltage: 1.7V to 5.5V
- Average Quiescent Current: 30uA (Typ.) for all channels at 1Con/s, VCC = 3.3V
- Standby Current: 3.0uA (Typ.)
- Temperature Accuracy without calibration for all channels: ±1°C from 0°C to 100°C
- 13 bit ADC for 0.0625°C resolution
- Digital interface compatible with SMBus and I²C
- Series Resistance Cancellation, n-Factor correction, Offset correction and Diode fault detection for each remote channel.
- Individually programmable THERM limit temperature for any of 5 channels with a share Hysterisis data
- Register lock feature to protection key register data
- 4 slave addresses available by setting AD0 pin
- Temperature Range:
 - 40°C to 125°C for sensor chip
 - 50°C to 150°C for remote diodes

Applications

- MCU, CPU, GPU, SOC, FPGA or DSP die or case Temperature monitor
- Desktop & Notebook Computer
- Server
- Telecom Equipment

PIN Configurations (Top View)

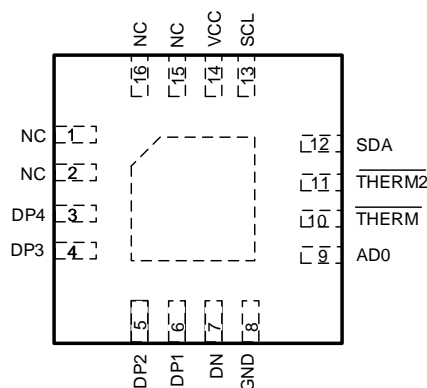

QFN3x3-16 (Package Code, QN)

Typical Application

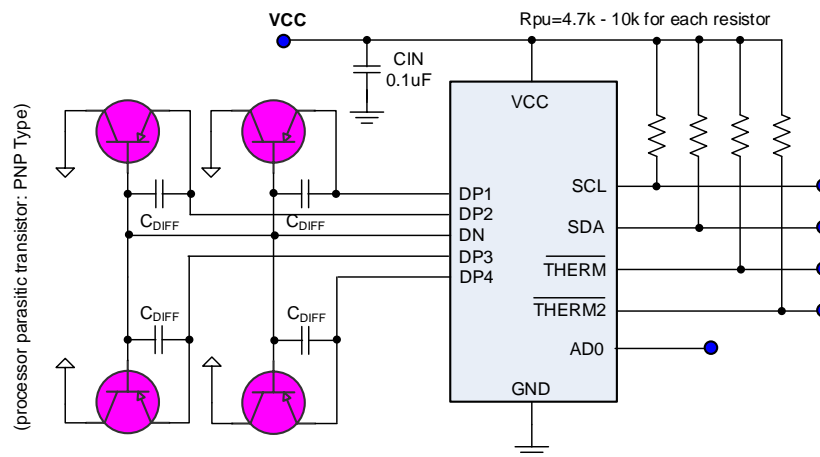

Figure 1. Typical Application of CT7424

Pin Description

PIN No.	PIN Name	Description
1	NC	No connection
2	NC	No connection
3	DP4	Remote channel 4 positive input pin, it could be positive node of Diodes, or BJT transistor (diode-connected mode). It is recommended to use bypass capacitor ($C_d < 1000\text{pF}$) plus serial resistor ($R_s < 1.0\text{k ohm}$) to remove noise between DP4 and DN pin.
4	DP3	Remote channel 3 positive input pin, it could be positive node of Diodes, or BJT transistor (diode-connected mode). It is recommended to use bypass capacitor ($C_d < 1000\text{pF}$) plus serial resistor ($R_s < 1.0\text{k ohm}$) to remove noise between DP3 and DN pin.
5	DP2	Remote channel 2 positive input pin, it could be positive node of Diodes, or BJT transistor (diode-connected mode). It is recommended to use bypass capacitor ($C_d < 1000\text{pF}$) plus serial resistor ($R_s < 1.0\text{k ohm}$) to remove noise between DP2 and DN pin.
6	DP1	Remote channel 1 positive input pin, it could be positive node of Diodes, or BJT transistor (diode-connected mode). It is recommended to use bypass capacitor ($C_d < 1000\text{pF}$) plus serial resistor ($R_s < 1.0\text{k ohm}$) to remove noise between DP1 and DN pin.
7	DN	Remote channel common negative input pin, it could be negative node of Diodes, or BJT transistor (diode-connected mode). It is recommended to use bypass capacitor ($C_d < 1000\text{pF}$) plus serial resistor ($R_s < 1.0\text{k ohm}$) to remove noise between DP1-DP4 pins and this pin respectively.
8	GND	Ground pin.
9	AD0	Slave address setup pin, there will be generate 4 different slave addresses by connecting to VCC, GND, SCL and SDA. Do not leave this pin open or float.
10	THERM	Open drain output with active low. Need a pull-up resistor to VCC, If the measured temperature meets or exceeds THERM-limit (programmable by user), this pin will be activated. This pin can be used to control Fan on/off.

$\pm 1.0^{\circ}\text{C}$ 5-CH (4-CH Remote and 1-CH Local) Digital Temperature Sensor

11	$\overline{\text{THERM2}}$	Another THERM (THERM2) pin, it is also open drain output with active low. Need a pull-up resistor to VCC. If the measured temperature meets or exceeds THERM2-limit (programmable by user), this pin will be activated.
12	SDA	Digital interface data input or output pin, need a pull-up resistor to VCC.
13	SCL	Digital interface clock input pin, need a pull-up resistor to VCC.
14	VCC	Power supply input pin, using 0.1uF low ESR ceramic capacitor to ground
15	NC	No connection
16	NC	No connection

Function Block

Figure 2. CT7424 function block

±1.0°C 5-CH (4-CH Remote and 1-CH Local) Digital Temperature Sensor
Ordering Information (Note 1)

Order PN	Accuracy	Green ¹	Package	Marking ID ²	Packing	MPQ	Operation Temperature
CT7424QNR	±1°C	Halogen free	QFN3x3-16	7424 YWWAXX	Tape & Reel	3,000	-40°C~+125°C

Note 1

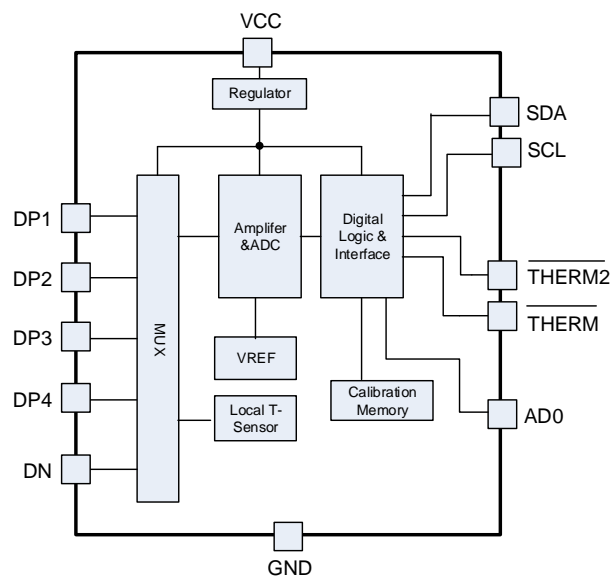
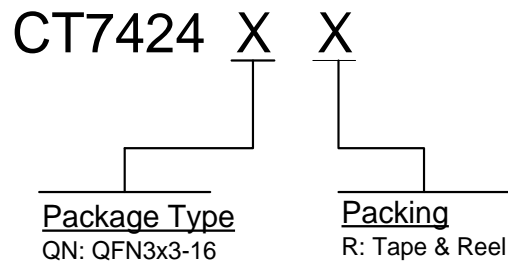
1. Based on ROHS Y2012 spec, Halogen free covers lead free. So most package types Sensylink offers only states halogen free, instead of lead free.

2. Marking ID includes 2 rows of characters. In general, the 1st row of characters are part number, and the 2nd row of characters are date code plus production information.

- 1) Generally, date code is represented by 3 numbers. The number stands for year and work week information. e.g. 501 stands for the first work week of year 2015; 621 stands for the 21st work week of year 2016.
- 2) Right after the date code information, the next 2-3 numbers or letters are specified to stand for supplier or production location information.



SENSYLINK Microelectronics Inc.

www.sensylink.com

IMPORTANT NOTICE

SENSYLINK Microelectronics Inc. reserves the right to make modifications, enhancements, improvements, corrections or other changes without further notice to this document and any product described herein or to discontinue any product or service. Customers should obtain the latest relevant information before placing orders and should verify the latest and complete information. SENSYLINK Microelectronics does not assume any responsibility for use of any product, nor does SENSYLINK Microelectronics any liability arising out of the application or use of this document or any product or circuit described herein. SENSYLINK Microelectronics assumes no liability for applications assistance or the design of Customers' products. Customers are responsible for their products and applications using SENSYLINK Microelectronics components. SENSYLINK Microelectronics does not convey any license under its patent or trademark rights nor the other rights.

SENSYLINK Microelectronics Inc. © 2015 - 2023.